



SS5000 WATER HEATER



Technical Description

Installation Instruction

Operating Instruction

Maintenance Instruction



SNUGGER CANADA

Snugger Heaters
Unit B-1465 Kebet Way
Port Coquitlam, BC
V3C 6L3
www.snuggerheaters.com
877-386-7320

CONTENTS

SNUGGER SS5000 WATER HEATER	02
OPERATING PRINCIPLE AND USE OF RANGE	02
INSTALLATION INSTRUCTIONS AND REGULATIONS	02
SAFETY INSTRUCTIONS AND OPERATION	03
TECHNICAL SPECIFICATIONS& DIMENSION	04
INSTALLATION POSITION	05
ENGINE COOLING SYSTEM AND HEATER HOSE CONNECTION	06
COMBUSTION AIR SYSTEM	07
EXHAUST SYSTEM	07
FUEL SUPPLY	08
OPERATING INSTRUCTIONS	11
DESCRIPTION OF FUNCTIONS	11
CONTROLS AND SAFETY DEVICE	11
ELECTRICAL SYSTEM	12
TROUBLESHOOTING MALFUNCTIONS AND MAINTENANCE	13
HEATER ASSEMBLY DRAWING	15
INSTALLATION COMPONENTS DIAGRAM	17

SNUGGER SS5000 WATER HEATER

Ss5000 water heaters are designed to be used as auxiliary engine heaters for trucks, RVs, boats, construction and farm equipment. In extreme cold temperatures, the heaters connect with the vehicle to preheat engines, defrost windows, warm cabs without the necessity of engines idling or frequent startups.

Automatic control keep the temperature of circulating water between 75°C-80°C, (167 -176). Compact design, low volume, easy maintenance, safety protection, auto self-diagnosis, optional timing, wireless remote control, low exhaust emission low operating cost make the heaters ideal to use in trucks, boats, farm and construction equipment.

OPERATING PRINCIPLE AND USE OF RANGE

• Operating principle

The fuel pump delivers fuel to the heater atomizer. The glow pin ignites the fuel-air mixture. Burning fuel heats up the heat exchanger. The heat is transferred into circulating water (coolant) through the heat exchanger, and the warm water (coolant) circulates through the engine block and the cabin heater core, defrost windows, warm cabs.

• Use of range

Widely used in water-cooled engines: cars, commercial and industrial equipment, trucks, passenger vans, buses, motor and sail boats, and houseboats. In addition, the heaters are used for heating water in RV's, travel trailers, cabins, watering carts, food service vehicles, and cleaning vehicles.

INSTALLATION INSTRUCTIONS AND REGULATIONS

• Installation

Select the location to place the heater in the engine compartment or truck cabin so that the heater exhaust gases will exhaust directly to the outside of the cabin or passengers space, through the floor or wall, and the heater water hoses can be easily attached to the cabin heater core lines. The top of the heater must be installed below the minimum engine coolant/water level to allow the air to escape and the heater to fill up with water/coolant when the bleed screw is open. Protect the heater from excessive heat, exposure, and possible contamination from fuel or oil. Keep heater exhaust away from electrical wires, fuel lines, water lines, and any other heat sensitive and flammable materials. Provide sufficient ventilation.

All precautions must be taken when arranging the heater placement to minimize the risk of injury or damage to property.

• Fuel Supply

The fuel intake connections shall NOT be in the passenger compartment or operator (driver) cabin. In vehicles where a separate fuel tank is used for the heater, the fuel tank lines and intake connection must be clearly identified. A warning sign shall be permanently attached to the intake connection or fuel tank indicating that the heater must be switched OFF before refueling.

• Exhaust System

The exhaust outlet must be arranged in a way to prevent penetration of exhaust fumes into the vehicle interior through the ventilation system, warm air intakes, or open windows, etc.

• Combustion Air Intake

The heater combustion air shall NOT be taken from passenger compartment, cargo space or operator (driver) cabin. The air intake shall be protected from possible water intake into combustion chamber, and cannot be blocked by any object at any time.

Please Note:

Failure to comply with the regulations, safety instructions, repairs done by unauthorized person, use of aftermarket parts voids warranty and relieves manufacture, distributors, dealers, and installation technicians from any and all liabilities.

SAFETY INSTRUCTIONS AND OPERATION

Disconnect vehicle battery power before commencing repair or performing heater maintenance. Before beginning any work on the heater, switch the heater OFF and let all hot parts cool down. The heater shall NOT be used in: poor ventilated rooms, garages, shops, multi-storage car park, etc. Use heater only in open, well ventilated areas.

Use of aftermarket parts is strictly prohibited unless authorized by the manufacturer. Installation and operation of the heater shall comply with statutory regulations, safety instructions and specifications as stated in the installation and operating instructions. Extreme precaution shall be taken when installing and maintaining electrical wiring, fuel supply, combustion air and exhaust system.

Unauthorized persons are not allowed to do any repairs or maintenance.

Debris or any other remains shall be removed and cleaned before reinstalling the heater into another vehicle.

The heater shall NOT be used in hazardous places such as but not limited to: fuel depots, carbon storage, timber warehouses, granaries and any other places where combustible or flammable vapor or dust may be present.

Heater must be switched OFF during refueling.

The heater shall be installed in a spacious compartment. Fuel canisters, oil cans, spray cans, gas cartridges, fire extinguisher, cleaning rags, clothing, papers, or any combustible or flammable materials shall NOT be stored or transported on or next to the heater.

Defective or burned fuses shall be replaced only with same type and same rating fuses.

In the event of a fuel leak; turn OFF the heater immediately, disconnect and cap off fuel line.

The leak shall be repaired by a professional, authorized technician.

Use only coolant liquids that are permitted by the vehicle manufacturer. Use of other coolants might damage the engine or heater.

Please note:

Do NOT prematurely shut down the heater by disconnecting the power unless required to do so by an emergency.

Warning:

Carbon monoxide monitoring sensor with alarm shall be installed in all passenger compartments, operator or driver cabin, and sleeper berth.

TECHNICAL SPECIFICATIONS & DIMENSION

MODEL		HYDTEC® SS5000			
Heating medium		Water, coolant			
Heat flow control		Super high	High	Middle	Low
Heating output (kW)		5	4	3.3	3
Fuel consumption (L/h)		0.61	0.49	0.4	0.37
Fuel		Diesel			
Power consumption (W)	Operating	51	43	40	37
	Start up	125 W			
Rated voltage (V)		12 V or 24 V			
Operation voltage range	Minimum voltage	10.5 V or 21V <small>(under-voltage protection will shut down the units when the voltage drops to this value)</small>			
	Maximum voltage	16 V or 32V <small>(over-voltage protection will shut down the units when the voltage rises to this value)</small>			
Allowable operation pressure		Max.2.0bar			
Water flow of water pump		1400L/h (When operating pressure is 0.14bar)			
Minimum water through-put capacity		500 L/h			
Allowable ambient temperature	Operating	-40°C - 80°C			
	Storage	-40°C - 85°C			
Weight (including controller and water pump except oil pump)		Approx 5kg			

Please note:

Listed technical data is subject to the tolerances of ± 10 %. Allowable Ambient temperature is 20°C.

• Dimension

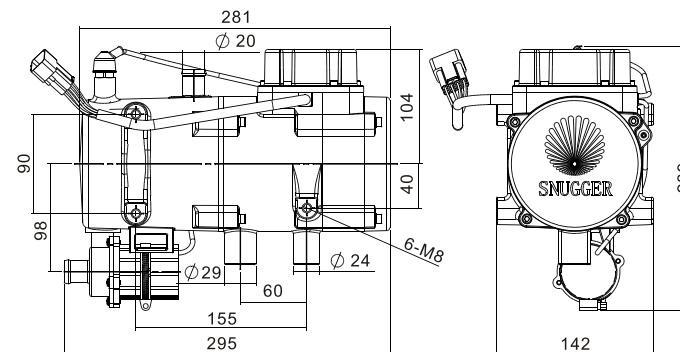

INSTALLATION POSITION

The best place to install the water heater is in the engine compartment; the heater must be installed below minimum engine coolant level (compensation container, cooler, heater exchanger of vehicle) in order to allow the air to escape.

Please note:

- Please considerate the installation way like the example illustration on truck.
- The illustration is only way to install heater, allow other installation position as long as meet the installation requirements.
- The installation of the boat or ship, may apply to the manufacture.
- Please note the installation angle, operating and storage temperature.

• Heater installation example

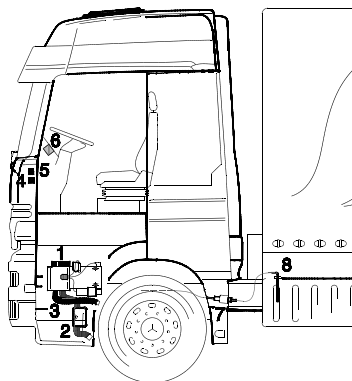

1. Ss5000 water heater
2. Exhaust pipe
3. Muffler
4. Fan relay
5. Fuse catch holder
6. Controll panel / 7 day timer
7. Fuel pump
8. Fuel tank adapting piece

• Tolerable swivel range

Depending on the installation conditions, swivel angles should be as shown below.

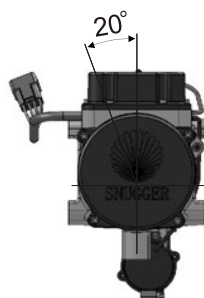
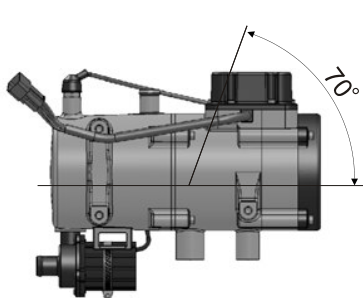

Please note:

In the heating mode, the heater can deviate from the shown normal or maximum installations positions by up to +15° in all directions in order to accommodate the vehicle or boat movement.

ENGINE COOLING SYSTEM AND HEATER HOSE CONNECTION

• Mode 1

Heater access with check valve in the cooling water circulation system as shown, cut off the water hose from engine to the heat exchanger, mounted the valve and hook up the hose to the valve.

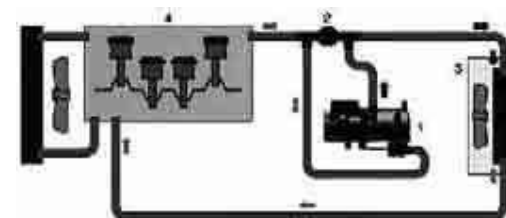

1—Heater 2—Valve 3—Heat exchanger 4—Engine

• Heater characteristic

Heater started, heating the heat exchanger and engine, when the temperature of water reaches 55°C, the fan will start automatically and heating the passenger compartment or cabin. Advantage: the heater shut off does not affect the car heating.

• Mode 2

Connect the heater between the engine and the cabin heater core as shown, cut water hose from engine to the heat exchanger, hook up the hose from engine to the inlet fitting of the heater (lower) and the other end of the hose (heater core side) into the heater outlet (upper).

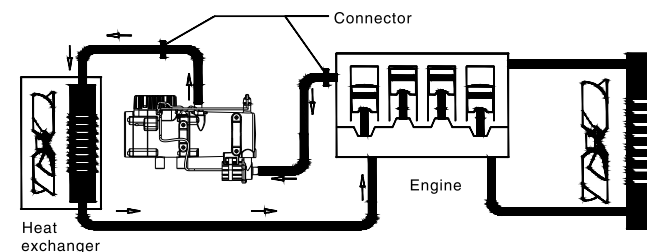

Please note:

- Heaters hoses and the hot air outlet shall be routed and fastened in such a way that they pose no risk to people or temperature sensitive materials.
- Before working on the coolant circuit, turn OFF the heater and wait until all components have cooled down completely; Always wear safety gloves and eye protection.
- Please take note of the direction of flow of coolant or water.
- Fill the heater and water hoses with coolant before connecting to the coolant circuit. Route the hoses in such a way as to avoid kinks, rubbing hoses against sharp corners, etc. Provide sufficient clearance to hot vehicle parts, and protect hoses from chafing

and rubbing against vehicle body. Use protective heat shields if necessary.

- Secure all hoses with hose clips. After operating the heater for 2 hours or engine running 100KM check for leaks and tight clamps as necessary.
- Maximum cooling circuit pressure shall not exceed 29 PSI (2 bar) not lower 5.8 PSI (0.4bar) and when water temperature difference between water inlet and water outlet must less than 10K to ensure the minimum water flow
- The coolant liquid must contain at least 10% antifreeze all year round as a corrosion protection.
- Before commissioning the heater or after changing the cooling liquid, the whole coolant circuit including heater must be free of air bubbles according to the installation instructions. To top off cooling system, use only coolants approved by vehicle manufacturer.

COMBUSTION AIR SYSTEM

• The installation of Combustion air system

Install the tube of the combustion air intake in such a way that the air intake is protected from sucking water, dust, hot air, exhaust fumes or any other debris into the combustion chamber. Inner hose diameter $\Phi 0.9"$ (24 mm). max. Length 55" (1.5 m), depending on the installation conditions.

EXHAUST SYSTEM

• The installation of exhaust system

The flexible exhaust pipe inner diameter of $\Phi(29\text{mm})$ can be shortened to no less than 8" (0.2m) from the heater to the silencer (muffler) but not longer than a total of 78" (2m) including muffler. Fasten the exhaust silencer (muffler) at suitable position to the vehicle frame, route the flexible exhaust pipe from the heater to the exhaust silencer and fasten with hose clamps. Use hose clips to attach the exhaust flex pipe to the vehicle body.

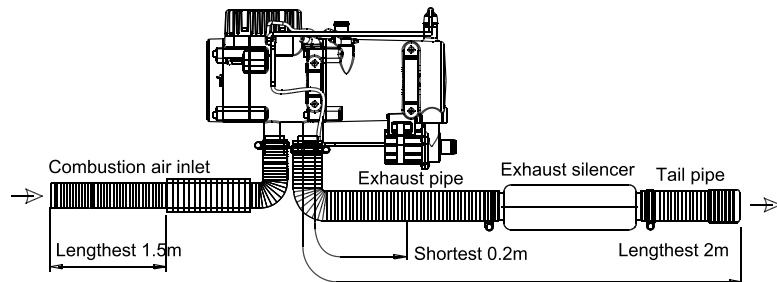

Warning:

- The entire exhaust system gets very hot during operation and immediately after the heater has been working. Keep the exhaust system parts away from any flammable materials. Wires, hoses, fuel lines, carpets, plastics, brake lines, etc.
- Maintain at least 1/2" air gap between the exhaust pipe and sheet metal walls in order

to prevent the heat transferring through the metal and damaging materials on the other side of the wall. Use heat shields if necessary. Point the heater exhaust tail pipe slightly downward, in open air, away from travel direction and at least 12' away from any combustible or flammable materials.

- Tail pipe cannot protrude beyond the lateral limits of the vehicle. Route the exhaust pipe in such a way so the exhaust fumes cannot be sucked into the vehicle.
- Do not perform any work on the exhaust system while the heater is working. Before working on the exhaust system, first turn the OFF heater and wait until all parts have cooled down completely, always wear safety gloves and eye protection.

FUEL SUPPLY

The following safety instructions must be observed when mounting the fuel pump, routing fuel lines and installing fuel tank pick-up tube

Turn OFF vehicle engine and heater before working on the fuel supply or before refueling. Do not use "naked" lights, open flames, do not smoke, do not inhale fuel vapors and avoid fuel contact with skin. Work only in well ventilated area.

When installing fuel lines, use only a sharp knife to cut fuel hoses and pipes. Interfaces shall not be crushed and must be free of burrs.

The fuel line from the pump to the heater should be installed at a continuous rise.

Fuel lines must be fastened to avoid damage and / or noise from vibrations.

Route the fuel lines in a way that they are protected from vehicle distortion, movement, etc. Never route or fasten fuel lines to the heater or vehicle exhaust system. When the fuel line crosses a hot element, always ensure there is sufficient clearance. If necessary, install heat deflection plates.

As shown in the figure, in case bubble in the connecting position, please make fuel pipe butt joint to fuel pump.

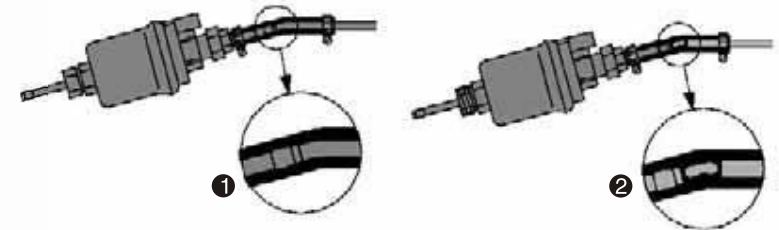

1. Connect correct 2. Wrong correct

• Safety Instructions for fuel pipes and fuel tanks in passenger compartment

In a passenger bus, fuel pipes and fuel tanks shall NOT be routed through the passenger compartment or operator or driver's cab. Fuel tanks in passenger vehicles must be positioned in such a way that the exits are not in direct danger from a possible fire.

• Fuel supply for diesel heater

Mode 1: Fuel line installation using T connector

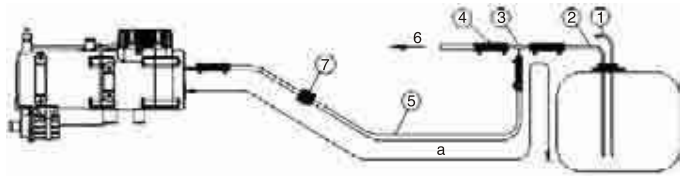

1. Fuel return pipe
2. Fuel tank pick-up tube
3. T fitting
4. Fuel line 4.5 x 3 (di = Φ 4.5mm) length 50mm
5. Fuel line max 5 x 1.5 (di = Φ 2mm)
6. To engine
7. Fuel pump allows the pipe length: suction side a \leq 5m

• Tfitting setting angle

Use the installation positions shown in the diagram when inserting a T fitting.

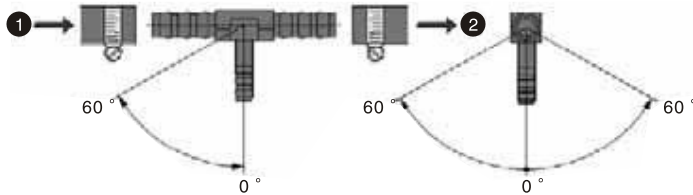

1. Direction of flow from the fuel tank
2. Direction of flow to vehicle engine

Mode 2: Fuel line installation with tank pick-up tube

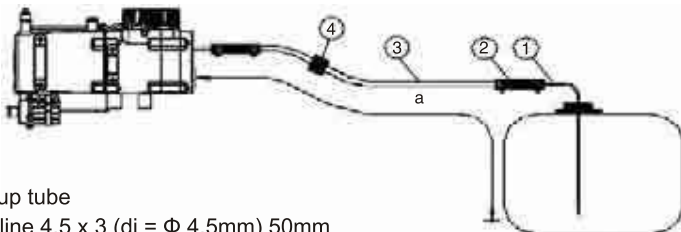

1. Tank pick-up tube
2. Black fuel line 4.5 x 3 (di = Φ 4.5mm) 50mm
3. Fuel pipe 5 x 1.5 (di = Φ 2mm)
4. Fuel pump allows the pipe length: suction side a \leq 5m

• Max. suction and pressure height

Max. height from fuel tank to heater

a = highest 12" (3000mm)

Max. suction height from bottom of tank

b = highest 1.95" (1000mm)

Max. height from fuel tank to heater when

the valve of cover has 0.03 bar pressure.

b = highest 400mm

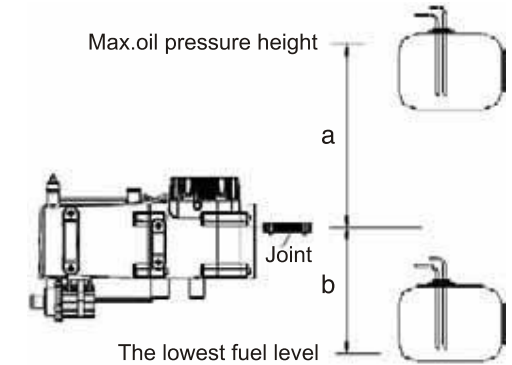

• Mounting of fuel intake system

Install method

Drill a 27mm hole in the appropriate location of fuel tank to install the fuel pick up pipe, as shown in figure 2 - 3.

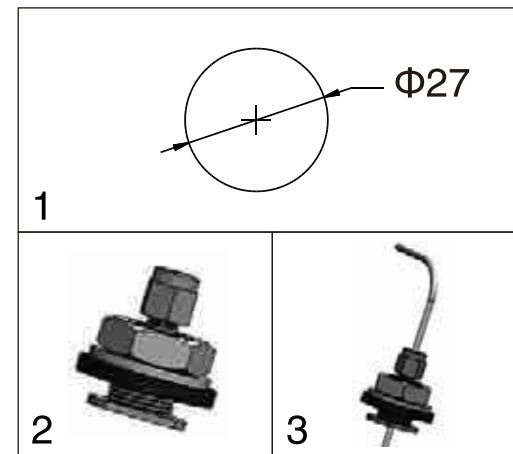

Please note:

When drilling into the fuel tank, take precautions to prevent possible sparks from electric tools (ground all tools).

Prevent shavings and any other debris to fall into the fuel tank.

OPERATING INSTRUCTIONS

Before starting the heater, perform a safety check: all components must be firmly fastened, check for fuel leaks, make sure the heater is filled with water or coolant (all air shall be bleed out). Bleed fuel line and prime fuel pump.

To start the heater; turn the thermostat to high (turn the knob clockwise), push heat bottom, the blower motor will start running. After about 45 sec. the fuel pump will start pumping. If the fuel is not ignited in about 90 sec. (possible air in fuel line) the glow pin will shut down for about 1 min. and then it will start the process again. The process will repeat until there is no more air in fuel line.

Heater at high altitudes:

1. Heating at altitudes below 5,000" (1,500m), -unlimited heating possible.
2. Using heater at altitudes higher than 5,000" (1,500m) requires installing an altitude pressure fuel pump.

DESCRIPTION OF FUNCTIONS

• Operation (when vehicle parking)

When the heater is turned ON, the control lamp comes ON. Water pump start pumping, combustion air blower starts running, glow pin starts heating up and fuel pump starts pumping fuel. Once the flame is stable, glow pin will turn off.

• Heating mode

According to the demand of heating, heater have three level, high-low-shut down.

Once the water reaches 175°C (85 °F) the heat will turn OFF, the combustion fan and water pump will continue to operate on the low speed. The heat light will stay ON. The heater will restart after water temperature drop below setting point. After the heater is turned OFF the exhaust fan and water pump will run for approximate. 2 min. In order to evacuate exhaust fumes and cool off the combustion chamber.

CONTROLS AND SAFETY DEVICE

If the heater does not ignite within 90 seconds after starting the fuel pump, the process repeats several times. After several unsuccessful starting attempts the controller will lock the system in order to prevent fuel flooding the chamber. You can restart the process by switching the heater OFF and then ON.

If the flame goes off during operation, the heater will restart by itself. If the heater does not ignite after several attempts, the heater will lock and it will need to be turned OFF and ON manually.

In the case of overheating (for example, lack of water, poorly vented coolant circuit), the overheating sensor is triggered, the fuel supply is interrupted and the heater turns OFF. Once the overheating has been eliminated, the heater can be restarted manually by turning OFF and ON again. The heater will turn ON when the water temperature drops below 158°C (70 °F). If the heater has been switched OFF and ON too many times, the controller will lock, wait for about 15 min. and turn the heater ON again.

If the lower or upper voltage limit is reached, the heater will turn OFF.

The heater does not start when the glow pin is defective or when the fuel pump power is interrupted.

The fan speed is continuously monitored. If the fan motor does not start or if the speed drop to less than 4C%, the heater will turn OFF after 60 sec.

The controller can be enabled again and it will flash fault code:

Use chart below to read the fault code list.

Do not switch the heater OFF and ON again more than twice.

Please note:

Emergency shut down.

In event of an emergency, shut down the heater as follows:

- Try to turn the heater OFF with the control panel.
- Pull the fuse out.
- Disconnect battery power.

ELECTRICAL SYSTEM

• Safety Instruction for wiring the heater

The Heater shall be connected to the power according to the EMC requirements. See instruction below.

Ensure that the electric cable's insulation is not damaged. Avoid: chafing, kinking, jamming or exposure to heat.

Seal all unused connector chambers with filler plugs to ensure there are not dirt enter into and water-proof.

All electrical connection shall be free of corrosion and firmly connected.

Lubricate al outside connections with contact grease.

• The heater circuit diagram

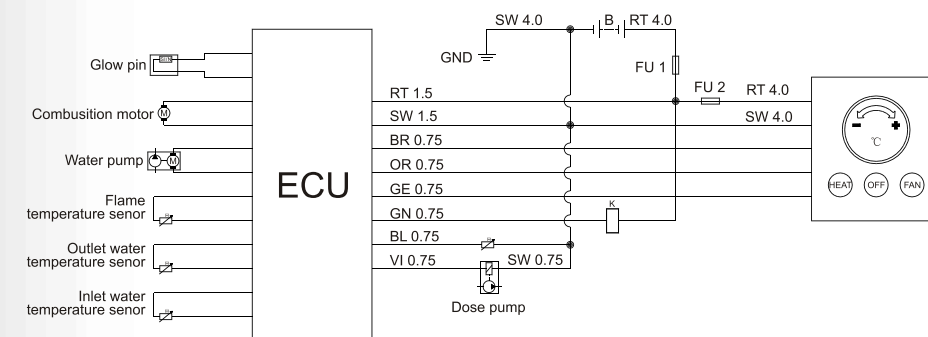

1. Control Principle Diagram

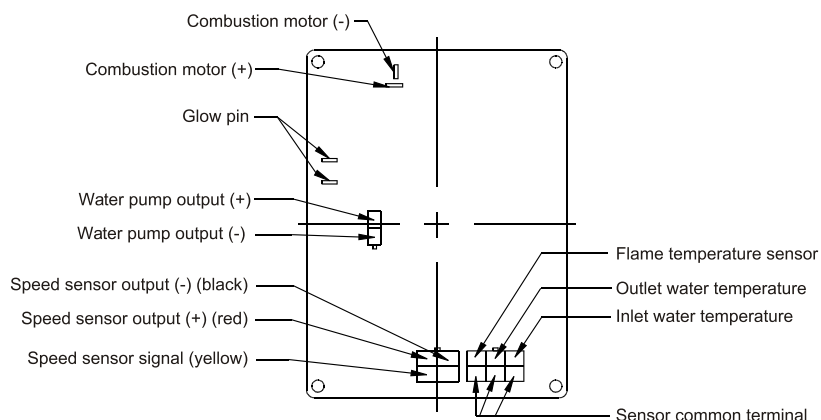

2 ECU Wiring Diagram

TROUBLESHOOTING MALFUNCTIONS AND MAINTENANCE

• Malfunction checklist

Heater does not start after being turned on; switch the heater OFF and ON again. If the heater still does not start, check the following:

- Is there fuel in the tank ?
- Are fuses ok ?
- Are electrical cables, all connections, etc OK ?
- Is anything clogging the combustion air supply or exhaust system ?
- Does the control panel flash the fault code ?
- To resets the system press down / OFF, button waiting for 15 minutes, it should clear the fault codes, turn ON the system. If the system does not clear the code, disconnect battery power, wait few minutes, hook up the battery power and turn the system ON.

• Maintenance Instructions

Switch the heater ON once a month for about 10 minutes, even if there is no need for heat. Check the opening of the combustion air supply and the exhaust system after longer standstill periods; clean if necessary.

Before the heating period starts the heater should undergo a trial run. If persistent extreme smoke, unusual burning noises, or an unburned fuel smell develop or if electric /electronic parts heats up, the heater shall be switched OFF immediately. Remove fuse or disconnect battery power.

Have the heater checked by authorized, trained service technician.

At least once a year have the heater checked by authorized, trained service technician.

Remove glow pin and atomizer; clean the screen and the atomizer chamber with wire brush, if notice that there is excessive carbon build up the entire combustion chamber shall be cleaned out.

Please note:

The warranty claims will become void if the heater is repaired or serviced by an unauthorized person.

• Water heater fault code

Code flashing times	Description	Solution
1 Time	The power supply voltage too high	Check the voltage, possible alternator drive belt too loose, check charging system
2 Times	The power supply voltage too low	Check the voltage, charge battery, check charging system
3 Times	The burner temperature abnormal	Check the temperature sensor connection and position whether it is correct Check the temperature sensor wires for possible damage or short
4 Times	Inlet water temperature sensor abnormal	
5 Times	Outlet water temperature sensor abnormal	
6 Times	Glow pin malfunction	Check the voltage between glow pin terminals it should read 12 or 24 V Check for broken wires and loose connection, short out wires Remove and check the glow pin for any visible damage; replace glow pin if damaged
7 Times	Fuel pump malfunction	Check voltage at fuel pump it should pulsing 12V / 24V Check wires for damage, check connections and shorted circuits Check fuel pump for any damage
8 Times	Blower malfunction	Check blower wires for damage and proper connections Check blower for any visible damage
9 Times	Water pump malfunction	Check wiring connections Check water pump for debris Check for cramped/collapsed hoses
10 Times	Lignite failed or flame extinguish protection	Check if there is fuel in tank Check all fuel line connections Check fuel pump if it is working Check the glow pin if it is working normally Check the air inlet/exhaust if it's not blocked
11 Times	Burner overheating protection	Check the fuel pump pressure Defective fuel injector Check water flow Check overheat sensor
12 Times	Outlet warm water temperature overheating protection	Check water level Bleed water system Check water flow Check warm water temp, Sensor
13 Times	Flame extinguished or burner overheating forbids the system operation	Check fuel pressure Check overheat temp, sensor Check water flow Disconnection power and re-connection again
14 Times	Communication fault	Check all wire connection.

HEATER ASSEMBLY DRAWING

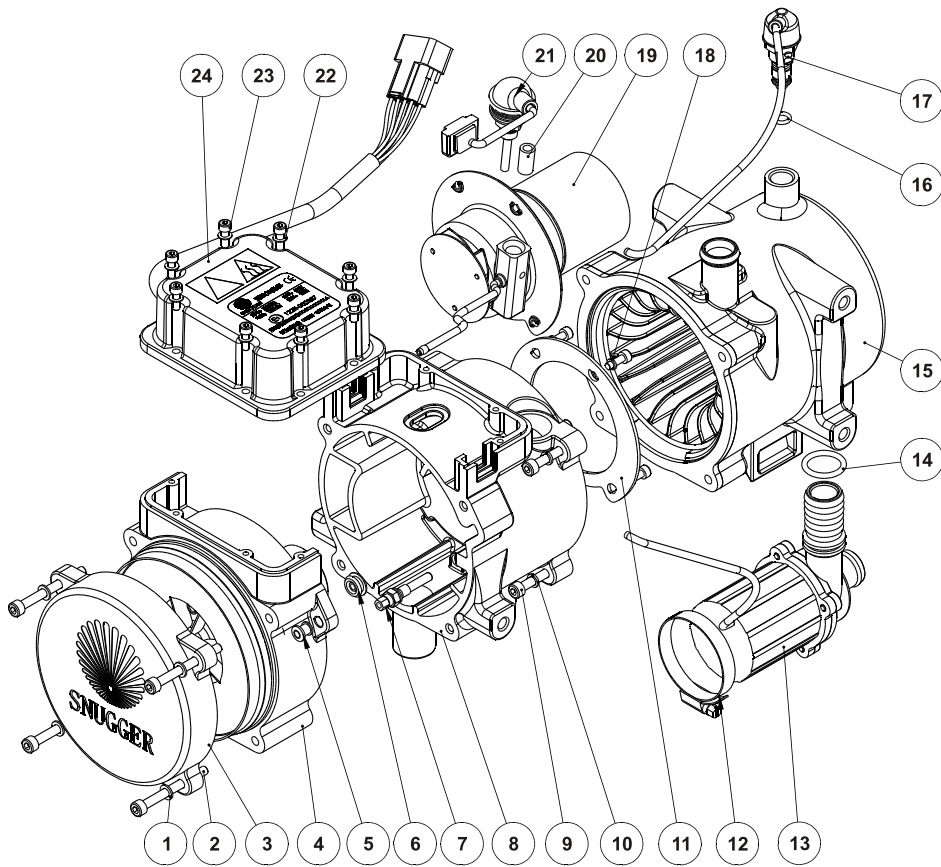

ITEM	P/N	DESCRIPTION	QTY
1	500015	Flat washer 5	4
2	010060	Hex screw M5x60	4
3	500008	Logo cover	1
4	500030A/B	Motor and fan assy	1
5	010025	Pipe cpmmector 1, fuel pipe	1
6	010026	Pipe cpmmector 2, fuel pipe	1
7	010012	Frame sensor	1
8	500006	Middle cover	1
9	500020	Hex screw M5x30	4
10	500022	Spring washer 5	4
11	010015	Spring washer	1
12	010057	Big Clamp 32-50	1
13	010036A/B	Water pump	1
14	010023	O ring, water pump	1
15	500031	Heat exchanger assy	1
16	010017	O ring, overheating sensor	1
17	010009	Overheating sensor assy.	1
18	500021	Spring washer 4	4
19	500011	Burners assembly	1
20	200115	Atomization net	1
21	010001A/B	Glow pin assy	1
22	500016	Flat washer 4	8
23	500017	Hex screw M4 x 12	12
24	500028A/B	Control unit	1

INSTALLATION COMPONENTS DIAGRAM

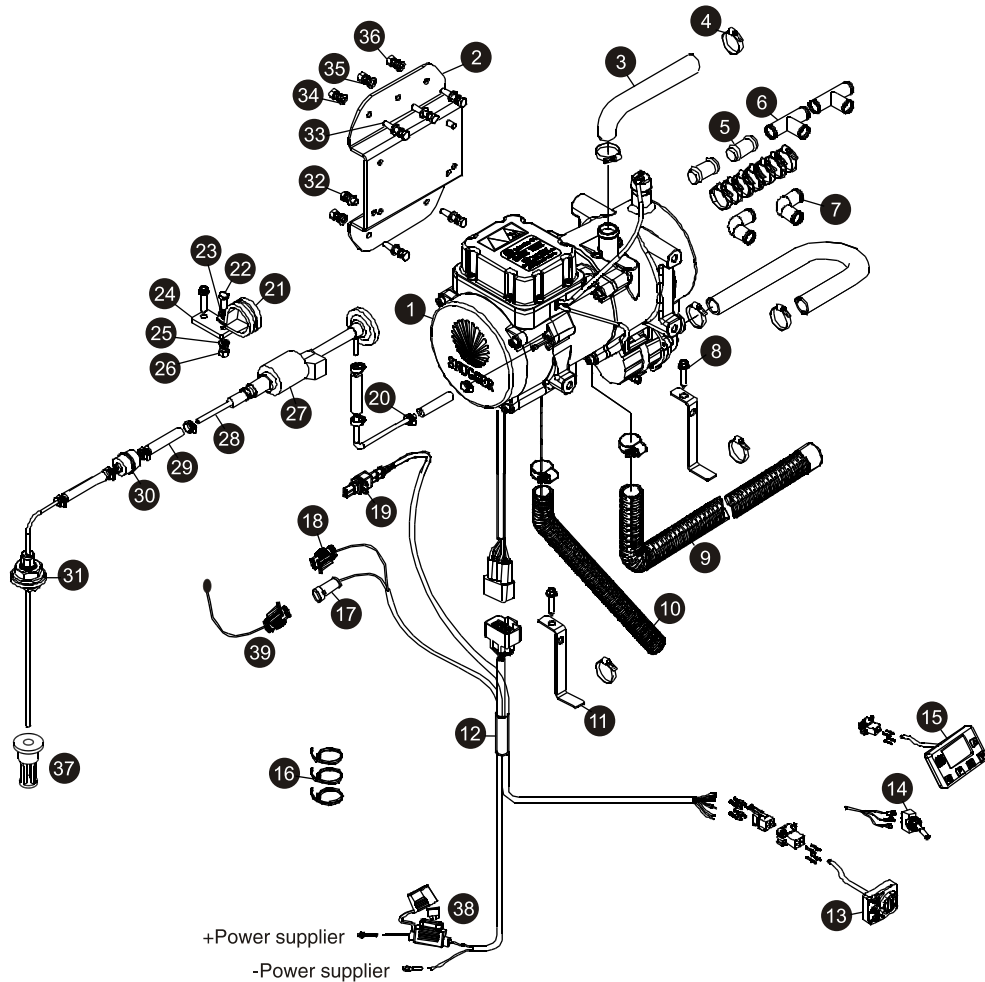

ITEM	P/N	DESCRIPTION	QTY
1	050000	Water heater	1
2	500027	Mounting bracket	1
3	042052	Water hose	3 m
4	500007	Clamp(Φ14-Φ32)	12
5	042401	Straight barb fitting	2
6	042403	T barb fitting	2
7	042402	90° deg barb fitting	2
8	500054	Hex self-tapping screw	4
9	500086	Exhaust pipe	1
10	010085	Air inlet pipe	1
11	230707	Hanging bracket for pipes	3
12	042501	Water heating controlharness	1
13	230610	Controlunit	1
14	230530	ON/OFF switch	1
15	230520	7-day timer	1
16	230411	Cable ties	25
17	042452	Temperature sensor	1
18	042451	Radiator controlharness	1
19	042503	Pump controlharness	1
20	042077	Clamp Φ9-11mm	10
21	500009	P-pipe elip (hose clip)Φ32	2
22	500045	Hex screw M6*30	2
23	500046	Spring washer 6	2
24	230706	Fuel pump damper	1
25	500047	Flat washer 6	4
26	500048	Hex screw M6	2
27	2301A/B	Fuel pump 125	1
28	230405	PA pipe OD Φ5.0mm*1.5mm	8 m
29	230406	Connecting hoses 50mm	5
30	042078	External filter PA pipe	1
31	230700	Fuel pickup tube pipe	1
32	500050	Hex screw M8*20	4
33	500049	Hex screw M8*40	5
34	500052	Flat washer 8	9
35	500051	Spring washer 8	9
36	500053	Nut M8	5
37	230501	Fuel filter, pickup tube	1
38	230601	Fuse(12V/20A24V/15A)	1
39	230320	Temperature sensor	1